

Since 1991 US Centrifuge has established itself as an innovative leader in centrifugal liquid / solid filtration technology. The New US Centrifuge Supramatic Model A560 automatic self-cleaning centrifuge is designed for a wide variety of tough processes and demanding liquid / solid separation / filtration applications where the specific gravity of the suspended solids are greater than that of the liquid. The proven design and highly efficient operation separates small micron solids from a liquid medium for the recovery of valuable solids or recycling of industrial fluids.

The Model A560 centrifuge is designed and built for safe, quiet, operation and years of reliable use in the most demanding applications while requiring relatively no day-to-day maintenance. The machines are American made and all engineering, manufacturing, service, and sales activities are located under one roof in Indianapolis for the convenience of our customers.

Supramatic Model A560 Machine Specifications:

- Bowl Volume 60.0 liter
- Max G-force 1,750
- Process capacity 5 to 75-gpm
- Max solids holding capacity 6.0 gallons
- Maximum clean cycles 6-cycles per hour
- Motor HP 15-HP
- Required feed pressure 10-psi @ 75-gpm
- Liquid inlet fitting 1" NPT
- Liquid discharge fitting 4" 150# Flange
- Liquid discharge pressure: Gravity return
- Maximum temperature 160°F
- Standard configuration 6 to 9-pH
- 316L Stainless configuration 2 to 14-pH

Exclusive Model A560 design features:

- Patented "Load Sensitive Dump" automation
- Patented "Centri-Lock" plow clutch
- Rotating feed distribution impeller design
- Rugged hi-torque gear driven plow systems
- Plow-blade assembly with Multiple blades
- Plow-blade assembly with efficiency ring
- Nu-Tride surface treated plow-blade assembly
- Rugged monocoque frame construction
- Rugged gear driven plow system

The centrifuge features fully automated operation that requires minimal operator attention. The standard Allen Bradley PLC based control panel controls provides maximum flexibility with a wide range of adjustable parameters so the machine can be tuned to suit the unique demands of each application. Panels also include industrial modems for remote monitoring, servicing, and upgrade capability.

The standard machine features a carbon steel powder-coated frame with an aluminum bowl-shell, stainless bowl-hub, and Nu-tride surface treated carbon steel plow-assembly. The machine is also available with all wetted surfaces constructed from 316L stainless steel.

Competitively priced with unequalled standard features and processing performance advantages

How the Supramatic Model A560 works:

The liquid continuously feeds down through the stationary feed pipe and into the throat of an abrasion resistant feed impeller, which distributes the liquid into the spinning centrifuge-bowl at an equivalent rpm due to the plow-clutch. The liquid enters the bowl at the bottom of the liquid pool surface and flows upward under increasing centrifugal force as it flows under the efficiency ring. The liquid then moves back toward the center of rotation and exits the bowl-hub discharge holes. As the liquid travels this path the separated solids deposit on the internal wall of the bowl shell forming a relatively moisture free solids cake, which is intermittently removed during the cleaning process. The liquid exiting the bowl-hub is captured the upper frame chamber and drains out the discharge fitting.

The length of a process cycle is application specific depending on the flow rate and percent solids in the incoming centrifuge feed liquid.

Once the centrifuge-bowl reaches it solids holding capacity the machine must stop and plow the centrifugally separated and compacted sludge cake from the bowl. When the machine transitions from the process cycle to the clean cycle it automatically closes the feed stop valve and activates the drive motor VFD resistor braking system powering the spinning centrifuge-bowl to a complete stop in 45 to 60-seconds. Once the unit has reached a complete stop the free liquid drains from the bowl into the lower frame chamber and flows back to the source. Actuators open the sludge chute cover and engage the ring and pinion plow gears. The plow-motor rotates the plow blades and bowl slowly back and forth in opposite directions as the solids are scraped out and fall through the sludge chute and into a hopper or drum placed below the unit.

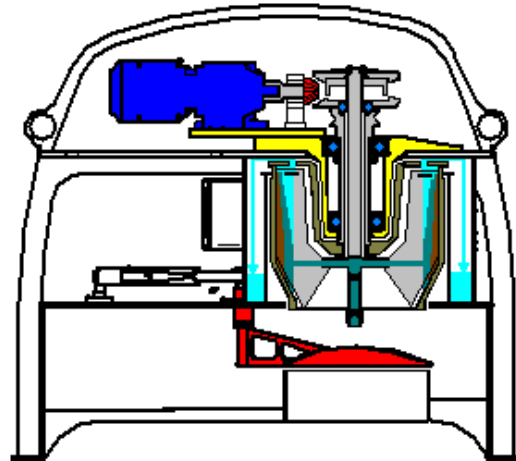

Liquid enters the liquid pool in the centrifuge bowl at nearly the same tangential speed reducing turbulence for better separation results

Separates particles as small as 2 micron

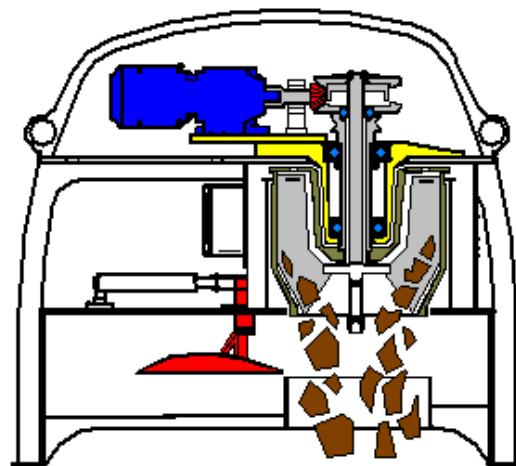

A typical clean cycle requires 3 to 5-minutes

The Model A560 automatic self-cleaning centrifuge represents US Centrifuge's latest innovations in leading centrifuge design technology with advantages not found on competitive units:



1. Rugged monocoque frame weldment fabricated from 2,550-lbs of heavy-duty plate steel and powder coated for added durability and longer working life.
2. Monocoque frame construction with integrated lift rings and forklift pockets for added convenience.
3. The separating power of up to 1, 750 x "G" is available by adjusting the drive motor VFD to suit the unique demands of each application.
4. Patented automatic "load sensitive dump" control for added process control and optimum machine performance.
5. Patented "Centri-Lock" plow clutch for maximum separating efficiency.
6. Simple bottom feed bowl design with abrasion resistant UHMW feed impeller integrated into the plow shaft assembly for maximum separating efficiency.
7. Durable hi-torque ring and pinion gear driven plow system to clean out the toughest cakes.
8. Plow-blade assembly with multiple blades and efficiency ring for maximum separating efficiency.
9. Dependable 24-volt electrically operated plow gear and sludge chute cover actuators.
10. Nu-Tride surface treated plow-blade assembly for added durability.
11. Advanced PLC based controls for maximum flexibility with a wide range of adjustable parameters so the machine can be tuned to suit the unique demands of each application.

The top feed bowl design combined with the highly abrasion resistant UHMW feed distribution impeller integrated into the plow-shaft assembly distributes and accelerates the incoming feed liquid to the centrifuge-bowl. **US Centrifuge's Patented "Centri-lock" plow clutch-hub system maximizes the machine's separating efficiency by maintaining a 1:1 rotation ratio between the plow-blade assembly and the bowl assembly, which minimizes internal liquid turbulence and increases separating performance.** The plow-blade assembly is manufactured with multiple plow-blades / impellers and an efficiency ring for added separating efficiency and maximum processing performance. The plow blades are laser-cut from 3/8" thick alloy steel plate and the entire assembly includes a standard Nu-Tride© surface treatment that hardens the plow blade face for added abrasion and corrosion resistance. Because all the major rotating assembly components are dual plane computer balanced, the centrifuge runs smoothly and quiet @ full RPM.

The separately driven ring and pinion gear plowing system is coupled to an SEW gearbox providing "Hi-Torque" plowing to discharge even the toughest solids cake from the centrifuge-bowl.

A major functional and operational advancement includes 24-volt electrically operated plow gear and sludge chute cover actuators. The electrically operated plow gear and sludge chute cover actuators are much more reliable and consistent than pneumatic actuated systems and completely eliminate the problems and issues associated with dirty and / or wet plant compressed air supplies.

Every Model A560 includes US Centrifuge's Patented Load Sensitive Dump "LSD" control technology, which automatically stops the machine when the unit has reached its maximum solids holding capacity and activates the clean-out cycle as required.

US Centrifuge offers two levels of centrifuge controls panels:

1. The standard automation package is a technically advanced deluxe control panel including an **Allen Bradley Micrologics 1100 PLC**, 256 color touch screen HMI operator interface, and VFD drive-motor control unit with resistor braking. This package is capable of accelerating the centrifuge to full speed in less than 40 seconds and stopping the unit smoothly in less than 60 seconds, which maximizes up-time processing by decreasing the clean cycle time. The panel also includes a VFD plow-motor control unit for controlling plow torque. The PLC and HMI include US Centrifuge's exclusive operating / display program that features complete operator instructions, help screens, self-diagnostics, and cycle history. And the standard control panel includes an industrial grade Internet modem for remote diagnostic and software upgrade capability.
2. Completely CUSTOM engineered and programmed automation packages and control panels can be designed and built to suit specific customer application and / or facility requirements at additional cost.

To minimize installation time and costs the centrifuge includes a machine-mounted auxiliary wiring box with a pre-wired flexible conduit wiring-harness and plug connectors that simply and quickly plug into the control panel. The only wiring required is connecting power to the control panel disconnect.

The centrifuge includes a mounting platform with high quality vibration isolators. A drum or hopper is simply place under the unit to catch the solids discharged from the centrifuge bowl. The clarified liquid gravity flows back into the process tank. Customized machine stands can be designed and constructed to suit customer requirements.

The units are designed for quick and easy disassembly for routine maintenance. The entire rotating assembly can be removed in 30-minutes and either rebuilt on site or shipped back to the US Centrifuge for a factory rebuild.

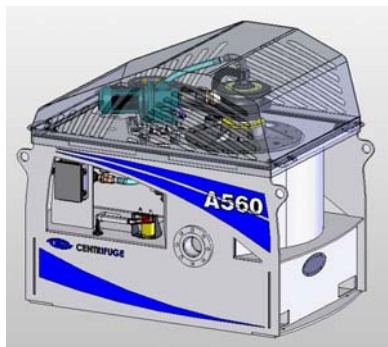

The Supramatic model A560 automatic self-cleaning centrifuge is ideal for a variety of fluid clarification / liquid recycling applications where other separation and / or filtration methods fail. A sample of successful applications include: Carbide cutting oils, Cold heading machine lubrication, Die lube, ECM EDM fluids, Glass and ceramic grinding coolants, Machining coolants, Ophthalmic lense grinding coolants, Parts washing fluids, Phosphate solutions, Quench oils, Screw machine oil, Thread and rolling oils, UF pre-treatment, Used oil clarification, Vibratory finishing, Industrial wastewater, Water wash paint booth, Aluminum and copper wire drawing fluids, and many more.....

General application benefits include:

- Automatic operation requires minimal time and attention
- Cleaner working fluids equal improved product quality
- Extended process liquid, media, and tool life
- Reduced production equipment downtime for maintenance and clean outs
- Minimized waste volumes with relatively dry drip free sludge and no consumable filter elements
- Environmental compliance

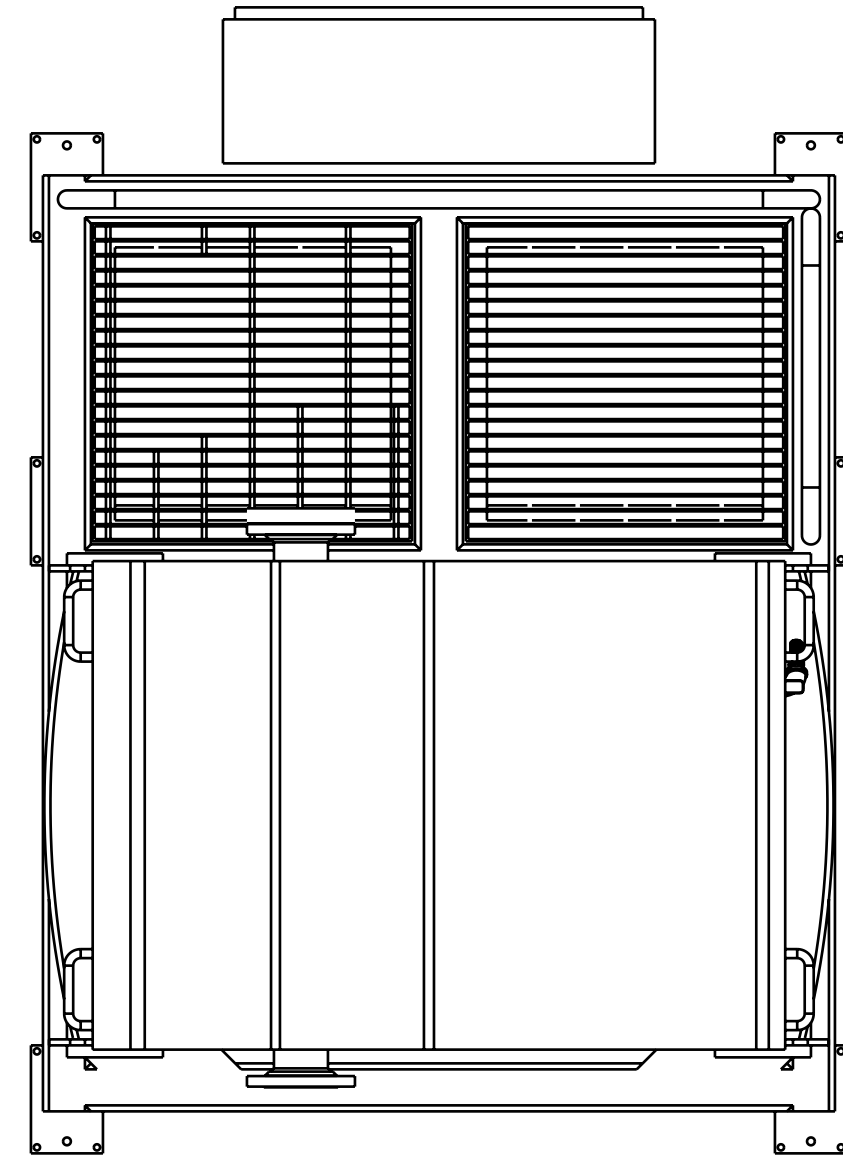

REVISIONS					
ZONE	LTR	DESCRIPTION	CHG.NO.	DATE	APPROVED

LAST LETTER USED:

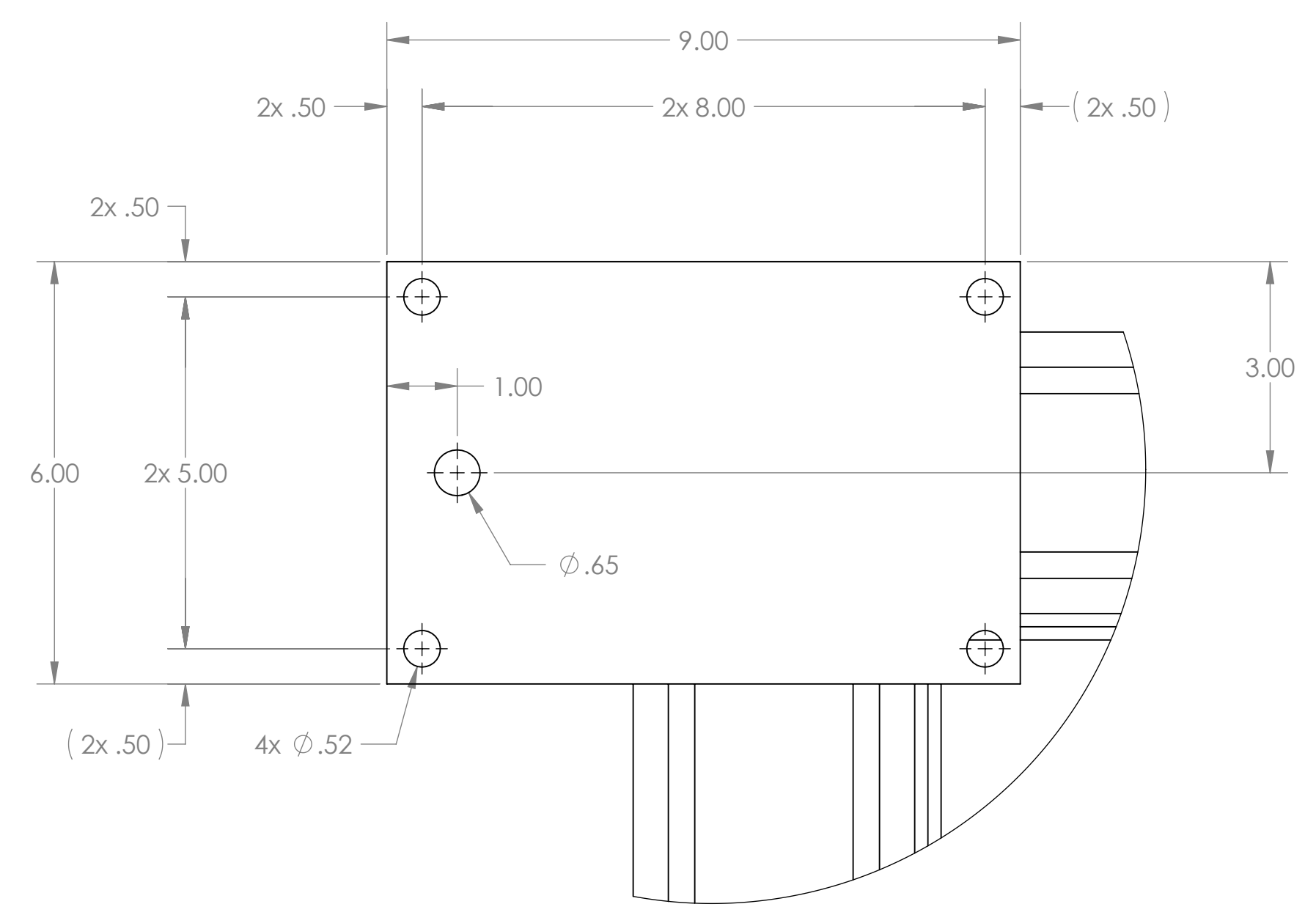

DETAIL A
SCALE 1 : 2

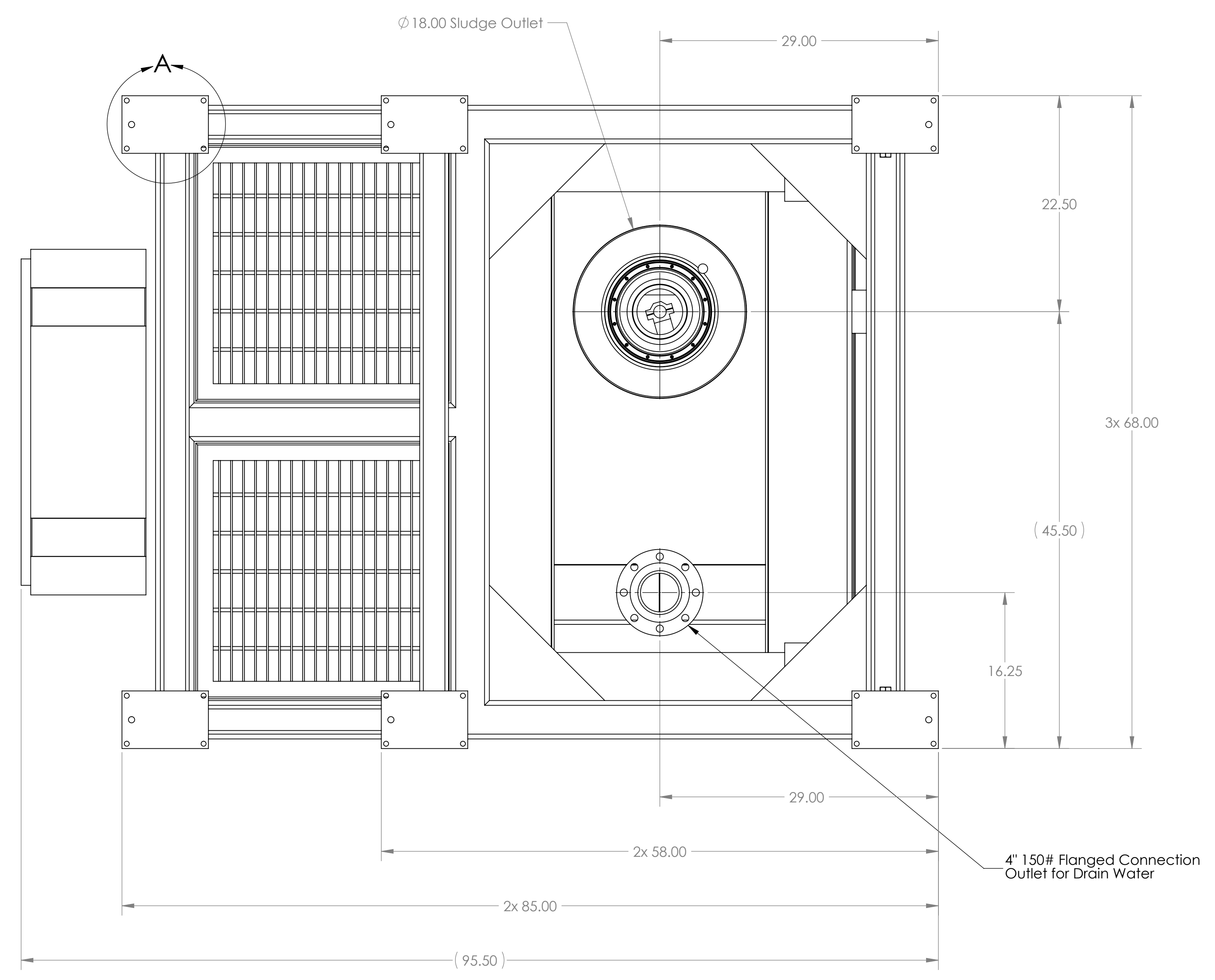

COMPANY CONFIDENTIAL
THIS DRAWING IS THE PROPERTY OF US CENTRIFUGE AND IT MUST BE ACCOUNTED FOR AND RETURNED UPON DEMAND. INFORMATION HEREIN IS COMPANY CONFIDENTIAL AND MUST NOT BE COPIED, REPRODUCED, DUPLICATED, DISCLOSED TO OTHERS IN WHOLE OR IN PART, OR SENT OUTSIDE THE COMPANY WITHOUT WRITTEN AUTHORIZATION.

		P1116A TITLE Installation Drawing A560 with Stand	
UNLESS OTHERWISE SPECIFIED DIMENSIONS ARE IN INCHES. TOLERANCE ON 2 PLACE 3 PLACE ANGLE ±.01 ±.005 ±0.30°		DWG NO.	
THIRD ANGLE PROJECTION		SEE NOTE	
Drawn Ken Forsha	DATE 10/10/06	SIZE D	REF.
Check S. BEHRENS	DATE	SCALE None	SHEET 1/1
NEXT ASSY APPLICATION	MODEL	MATERIAL:	