

REVISIONS					
ZONE	LTR	DESCRIPTION	CHG.NO.	DATE	APPROVED

LAST LETTER USED:

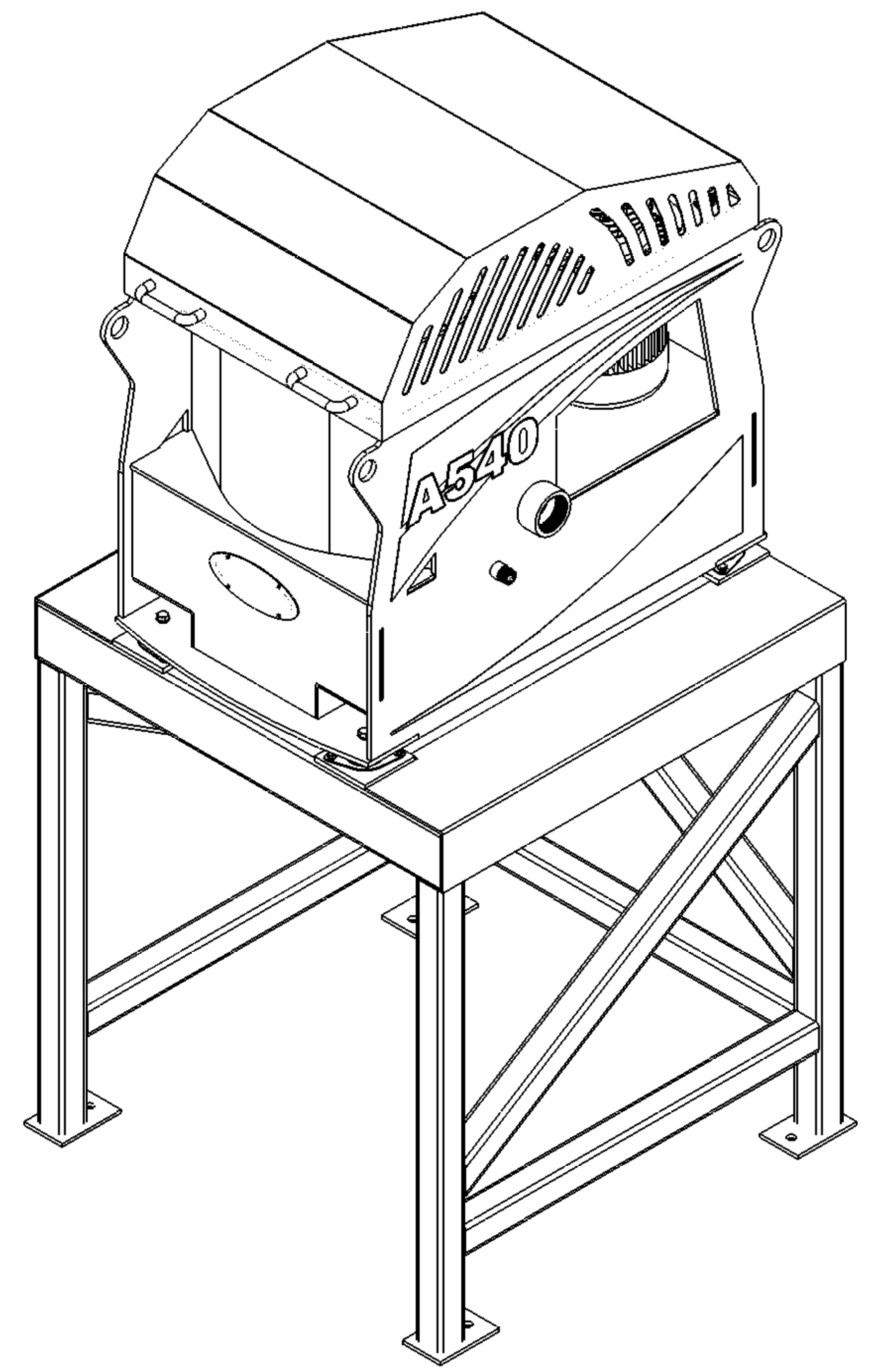
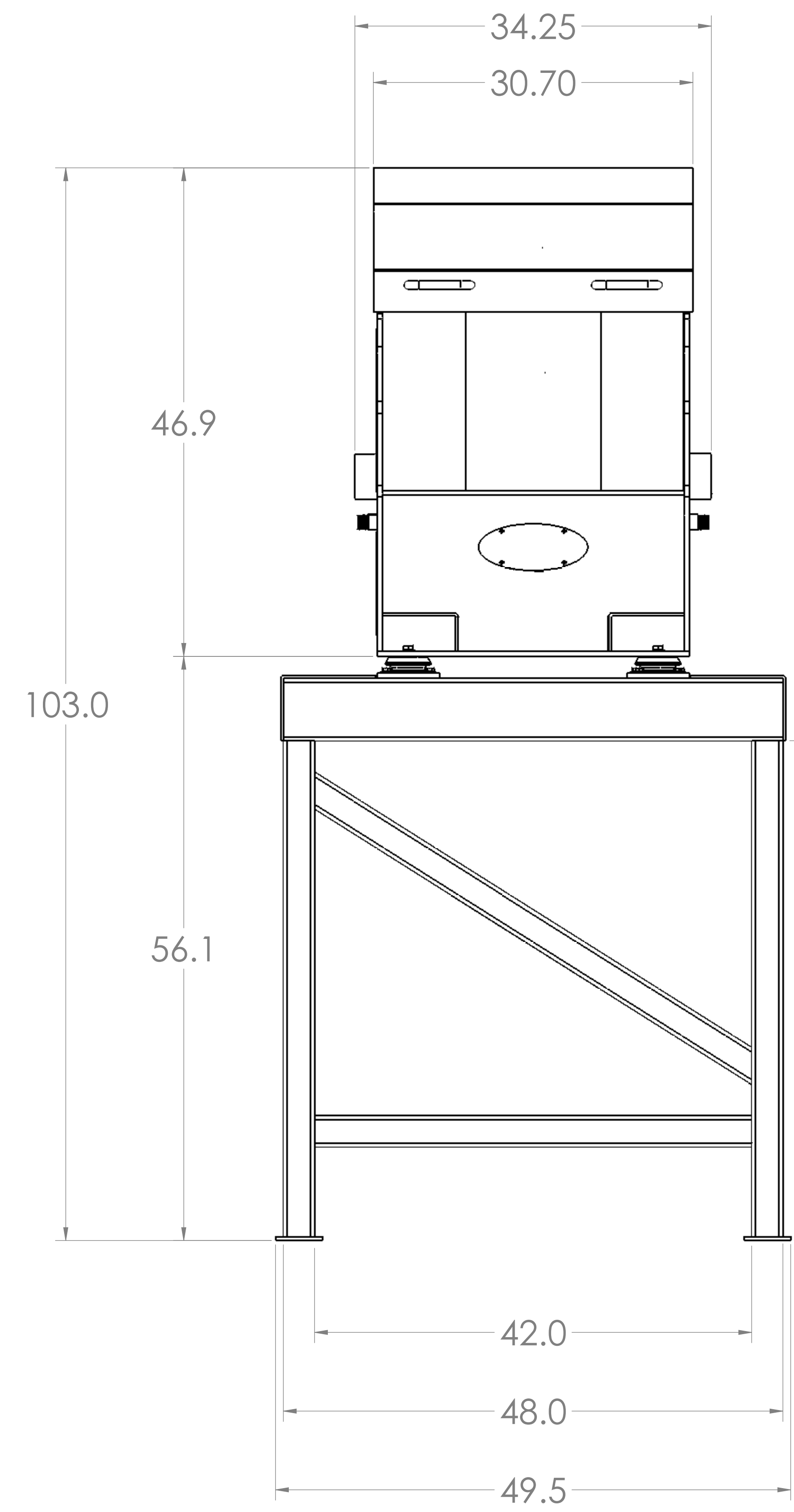
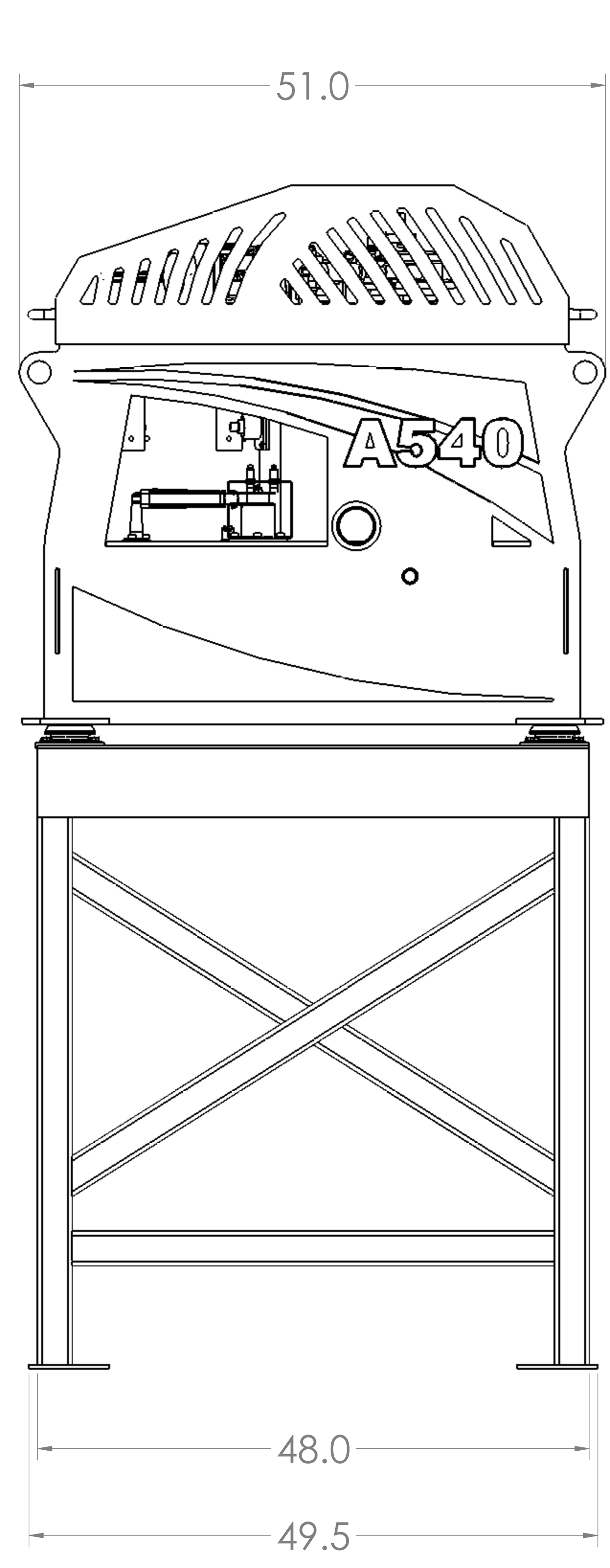

COMPANY CONFIDENTIAL

THIS DRAWING IS THE PROPERTY OF US CENTRIFUGE AND IT MUST BE ACCOUNTED FOR AND RETURNED UPON DEMAND. INFORMATION HERIN IS COMPANY CONFIDENTIAL AND MUST NOT BE COPIED, REPRODUCED, DUPLICATED, DISCLOSED TO OTHERS IN WHOLE OR IN PART, OR SENT OUTSIDE THE COMPANY WITHOUT WRITTEN AUTHORIZATION.

		DWG NO. P2021A	
The Liquid-Solid Separation Experts		TITLE A540 Centrifuge with Support Stand	
UNLESS OTHERWISE SPECIFIED DIMENSIONS ARE IN INCHES. TOLERANCE ON 2 PLACE 3 PLACE ANGLE ±.01 ±.005 ±0.30°		THIRD ANGLE PROJECTION	
MATERIAL: SEE NOTE		DATE 3/13/07	
Drawn Ken Forsha		Check S. BEHRENS	
NEXT ASSY APPLICATION		SCALE None SHEET 1/1	